

По вопросам продаж и поддержки обращаться:
Астана +7(7172)727-132, Волгоград (844)278-03-48, Воронеж (473)204-51-73,
Екатеринбург (343)384-55-89, Казань (843)206-01-48, Краснодар (861)203-40-90,
Красноярск (391)204-63-61, Москва (495)268-04-70, Нижний Новгород (831)429-08-12,
Новосибирск (383)227-86-73, Ростов-на-Дону (863)308-18-15, Самара (846)206-03-16,
Санкт-Петербург (812)309-46-40, Саратов (845)249-38-78, Уфа (347)229-48-12
Россия, Казахстан и другие страны ТС. Доставка в любой город
Единый адрес для всех регионов: enk@nt-rt.ru || ermaksan.nt-rt.ru

Innovative Technologies.



HGD SERIES
Hydraulic Swing Beam Shear

ERMAKSAN
SHEET METAL WORKING MACHINERY



80.000 sqm

Largest manufacturing facility under one roof in Europe in its sector.



ERMAKSAN is well known for productive and result oriented research & development activities as well as affordable high-tech products in fabricating industry. With 47 years of manufacturing experience ERMAKSAN continuously invests on latest technology and its human resources.

ERMAKSAN manufactures 3000 machines annually with 700 qualified staff in a fully modernized 80.000 sqm factory equipped with state-of art machinery. ERMAKSAN exports 80% of its production through agents under the brand ERMAK from Canada to New Zealand, more than 70 countries in the world and provides full technical support since 1965.

By purchasing ERMAK machines, you will be investing on your future. With this decision we promise you to deliver the machine which will suit your needs and provide the best purchasing experience by means of price, delivery, quality, training and after-sales technical support.

ERMAKSAN
SHEET METAL WORKING MACHINERY

InnovativeTechnologies.



28.000

Machining capacity of 28.000 mm
single part.



3.000

3.000 machines manufactured annually.

HGD SERIES

Hydraulic Swing Beam Shear

ERMAKSAN, known as one of the top world wide manufacturers in sheet metal industry, proudly announces its latest shear model to the market, which we call it Hydraulic Swing Beam Shear "HGD".

ERMAKSAN, HGD Series shears are designed superiorly for sheets 6-20 mm with high quality material and workmanship and produced to be used several years in heavy duty without any problem.

Strong monoblock steel weld construction frame retains its rigidity even working in maximum capacity, thus helps to provide a good quality and clean cut.

Cybtouch 6.

Designed for easy operation that allows comfortable working with high-resolution color touch screen.

Impressive cutting solutions;

Highly durable upper and bottom blades create impressive cutting surface on the materials and allow you to make perfect cuts.



Impressive cutting solutions



Front support arms.

1 meter (39)" long, measured by mm/inch strong front support arms with T slot and stopper.

Rigid structure.

Processed with high precision, dynamic and static rigidity provided strong body.

Cutting is so easy now

Standard Equipments

- Hardened blades.
 - Top blades : 2 sides
 - Bottom blades : 4 sides
- CYBELEC CYBTOUCH 6 controller.
- 350 mm throat depth.
- 1000 mm motorized backgauge system with 0,1 mm accuracy.
- 1000 mm side gauge and front support arms.
- Metric and inch rulers.
- Front, side and back safety panels which are suitable for CE norms.
- Sheet sliding system.
- SIEMENS electrical system.
- Hoerbiger hydraulic system.
- Holder springs.
- Moveable foot pedal.
- Manual blade gap adjustment.
- Emergency stop button.

Optional Equipments

- Optional throat depth.
- Front angle gauge.
- Side gauge and front support arms in optional lengths.
- Sheet conveyor and stacking system.
- Front Gauge X1, X2 axis and backgauge X3, X4 axis.
- Optional backgauge stroke.
- Sheet support system for thin sheets.
 - 1- Pneumatic support system. (Lever type)
 - 2- Pneumatic support system. (Monobloc panel type)
- Moveable controller panel, multi functional CNC control unit.
 - 1- CYBELEC DNC 61G
- Hydraulic blade gap adjustment system.
- Hydraulic oil cooling and heating system.
- Optional solid table.
- Stainless steel blades.
- Ability to increase stroke amount per minute.
- Light safety system for finger protection.
- Optional alternative colors.
- Coollant system or heater can be placed in electric panel during ambient conditions.
- Double foot pedal.
- Electrical panel or controller can be placed on right side of the machine.
- Laser cutting line.
- Central lubrication system.



Motorized back gauge system.
1000 mm long back gauge with
0,1 mm accuracy.

Rear sheet sliding plates.
Cutting parts are carried out rapidly to the
back side of shear.

SICK M 2000 light barrier.
Fast and secure protection at all time
compatible with CE standards.

Movable controller arm.
Allows operators to concentrate on job.

ERMAK

HGD 3100 X 10

Shadow line.
Provides qualified and sensitive cutting by casting a line shadow at the cutting edge for right positioning of the worksheet to be cut.

Foot pedal.
Dual positioned pedal allows you to cut automatically.



Perfect design in every aspect;

ERMAKSAN improves its reliability every day working with highly educated engineers and by using the latest technology in rapidly developing sheet metal industry.



Front finger protection.
Finger protection that matches with international safety standards, presents a great visual working area to operator.

Emergency stop buttons.
Easily reachable buttons.

Light curtains for finger protection.
Designed to enable easy and quick material handling with high-protection.



General features (Cybtouch 6, standard)

User - friendly:

- Wide, bright, colorful touch screen to program easily.
- Easy control pages.
- Complete part programming in seconds.
- Quick machine set up with EASYCUT page.
- Contextual help and warning pup-up.

Improved features:

- Auto shutdown function for energy saving.
- 10 different language selection.
- Working time.
- Wireless communication via PC/Laptop (optional).
- Backgauge auto-retraction programming.

Better cuttings:

- Automatic calculations of cutting functions upon material specifications.
- More cutting sequence and programming memory.





Squaring arm.

Makes it easy to handle the work and feeds the material through the cutting area by providing more delicate and quicker cuttings.

Collapsible finger protection.

In order to control angled cuttings and drawn lines front part of protection can be pulled up by operator. Switch protected.

Under your control

General features (Cybelelec DNC61G, option)

User - friendly:

- Ergonomic design.
- Rapid data input with the ergonomic keyboard with large keys.
- Easy set up and use that meets operator's needs.
- Keyboard with big buttons.
- Programmed material types.
- Monochrome 130 x 75mm LCD Box Panel.

Improved features:

- Blade gap, cutting angle and cutting length adjusted based on material selection and thickness automatically.
- Different language selections.
- Highly protected micro processor.
- Data recording with internal SRAM memory.
- Updateable with flash memory (optionally with RS 232).
- EASYCUT page.
- Numerically programmable axis data.
- 16 input and output ports (24-32 options).
mm/inch conversion

Better cuttings:

- Backgauge adjustment according to blade gap.
- Backgauge retraction feature.
- Sub-program and programming loop.
- Sequence repeat function.
- Auto cutting (Flying cut).



Equipments

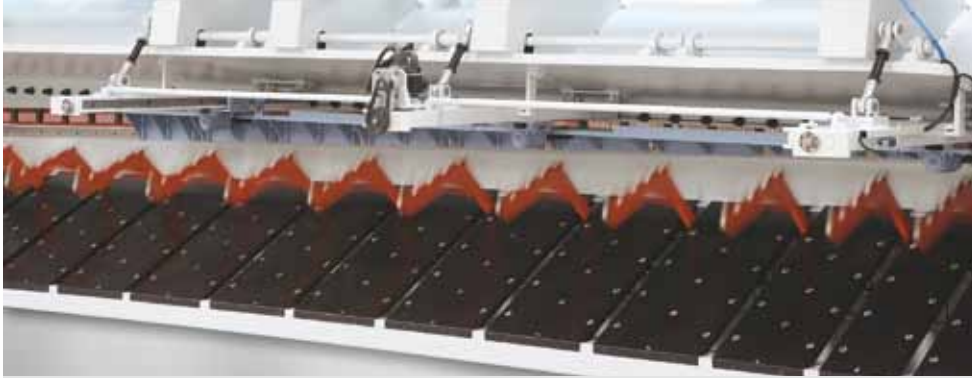

Pneumatic support system. (Lever type). (option)

Pneumatic sheet support system provides user an easy method of working, is an optional function to protect sheets hanging down and to improve precision during long and thin sheets cutting with minimum scratches through plastic rolls on pneumatic sheet support system.



Pneumatic support system. (Monobloc panel type). (option)

Helps positioning thick and thin sheet metals with sensitive reinforced pneumatic system structure without sagging.

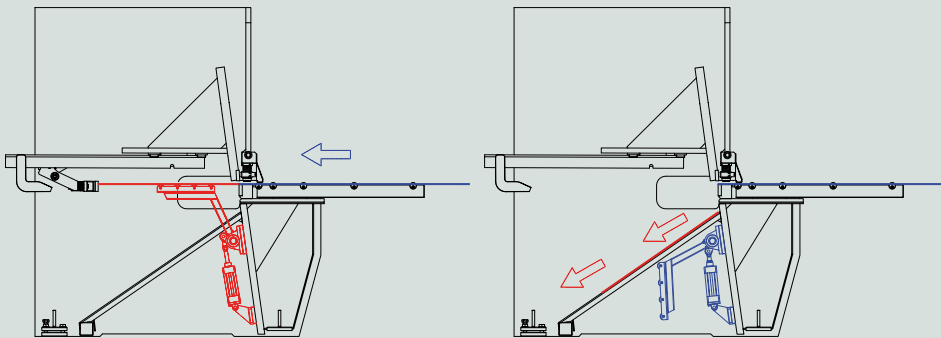

Pneumatic support system working principle. (Lever type)

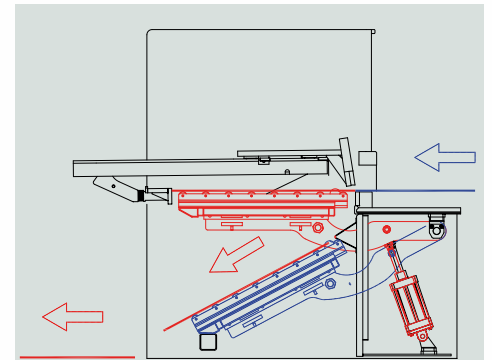

Pneumatic support system working principle. (Monobloc panel type)



Squaring arm.

Makes it easy to handle the work and feeds the material through the cutting area by providing more delicate and quicker cuttings.



Throat. (standard)

350 mm standard throat depth allows you to cut sheet metals that are longer than machine length.

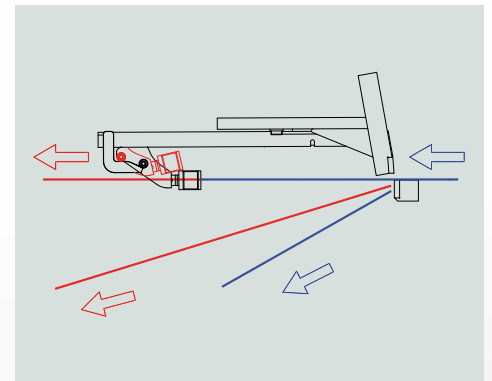

Swing-Up back gauge. (standard)

Enables to cut sheet metals that are longer than backgauge stroke.

Equipments



Light curtains for finger protection. (option)

Designed to enable easy and quick material handling with high-protection.



Laser cutting line. (option)

With the help of laser cutting line, angled or drawn line cuttings could be done easily and controllable.



Shadow line. (standard)

Provides qualified and sensitive cutting by casting a line shadow at the cutting edge for right positioning of the worksheet to be cut.



Front sheet metal feeding system. (option)

Adjustable width, high accurate and fast front metal sheet feeding system will increase your productivity.



Angle gauge. (option)

This device provides accurate and easy material handling in the angled cuttings.



Collapsible finger protection. (standard)

In order to control angled cuttings and drawn lines front part of protection can be pulled up by operator. (Switch protected)

HGD SERIES

Hydraulic Swing Beam Shear

Technical Features

TYPES	CUTTING LENGTH	CUTTING CAPACITY (42kg/mm ²)	CUTTING CAPACITY (70kg/mm ²)	CUTTING ANGLE	STROKE PER MINUTE	NUMBER OF HOLD DOWNS	PRESSURE	MAIN MOTOR	BACK GAUGE MOTOR	BACK GAUGE STROKE	BACK GAUGE SPEED
	A										
	mm	mm	mm	(°)	1/min.	Amount	ton	kW	kW	mm	mm/s
HGD 3100 - 6	3100	6	4	1.5	16	14	12	11	0.75	1000	110
HGD 3100 - 8	3100	8	5	1.5	14	14	24	18.5	0.75	1000	110
HGD 3100 - 10	3100	10	6	2	13	14	24	22	0.75	1000	110
HGD 3100 - 13	3100	13	8	2	11	14	31	22	0.75	1000	110
HGD 3100 - 16	3100	16	10	2.5	10	14	42	30	1.1	1000	110
HGD 3100 - 20	3100	20	13	2.5	8	14	54	37	1.1	1000	110
HGD 4100 - 6	4100	6	4	1.5	14	18	15	11	0.75	1000	110
HGD 4100 - 8	4100	8	5	1.5	12	18	28	18.5	0.75	1000	110
HGD 4100 - 10	4100	10	6	2	10	18	28	22	0.75	1000	110
HGD 4100 - 13	4100	13	8	2	9	18	40	22	0.75	1000	110
HGD 4100 - 16	4100	16	10	2.5	8	18	52	30	1.1	1000	110
HGD 4100 - 20	4100	20	13	2.5	7	18	67	37	1.1	1000	110

Shear Series

ERMAKSAN proven experience in the world since 1965 by using high-tech manufacturing technologies CNC HVR, HGD and HGS-A models are brought the sheet metal working market.

ERMAKSAN, improves its reliability every day by working with highly educated engineers and by using the latest technology in rapidly developing sheet metal industry. By using world standard steel, hydraulic systems and electronic products all your production needs provided.

Your needs are met with different options by fast, flexible and the most appropriate way.

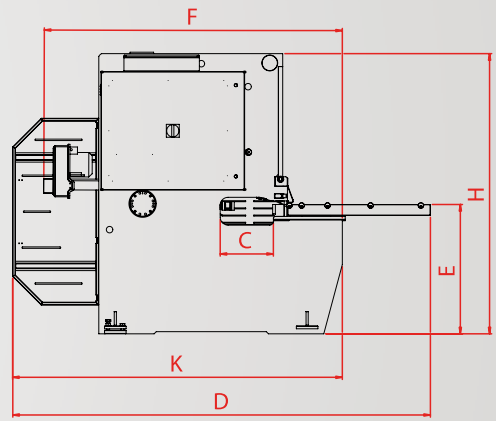
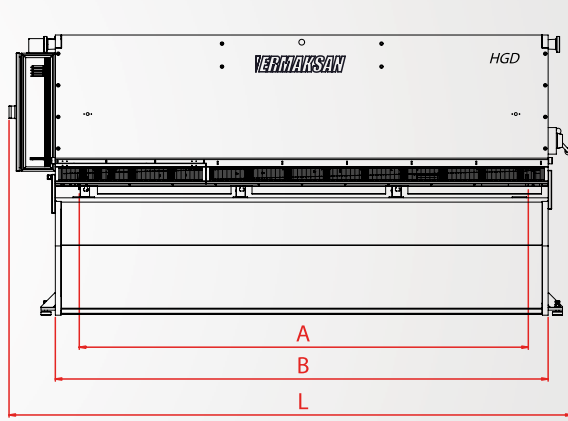

OIL CAPACITY	BLADE GAP ADJUSTMENT	NUMBER OF SHEET SUPPORT ARMS	TABLE LENGTH	THROAT DEPTH	MACHINE WIDTH	TABLE HEIGHT	WIDTH	TRANSPORT WIDTH	HEIGHT	LENGTH	WEIGHT
lt.	mm	Amount	B	C	D	E	K	F	H	L	kg
150	0,05-0,8	2	3430	350	2900	900	2315	2100	2100	3925	7300
250	0,05-1,0	2	3480	350	2970	900	2430	2150	2125	4000	9000
260	0,05-1,3	2	3480	350	3075	900	2500	2270	2175	4050	9400
310	0,05-1,5	2	3530	350	3150	900	2625	2325	2235	4100	12000
500	0,05-1,9	2	3620	350	3150	900	2625	2360	2450	4150	16100
500	0,05-2,3	2	3690	350	3250	900	2700	2380	2500	4350	22300
150	0,05-0,8	3	4430	350	2900	950	2315	2100	2150	4900	9500
250	0,05-1,0	3	4480	350	2960	950	2430	2150	2175	5000	11850
260	0,05-1,5	3	4480	350	3125	1000	2570	2275	2275	5050	13150
310	0,05-1,5	3	4530	350	3130	1000	2670	2350	2335	5100	16000
500	0,05-1,9	3	4620	350	3150	1000	2610	2360	2575	5200	24500
500	0,05-2,3	3	4690	350	3200	1000	2670	2380	2600	5250	27750



CNC HVR SERIES
Variable Rake Hydraulic Guillotine Shear



HGD SERIES
Hydraulic Swing Beam Shear



HGS-A SERIES
Hydraulic Swing Beam Shear

По вопросам продаж и поддержки обращаться:

Астана +7(7172)727-132, Волгоград (844)278-03-48, Воронеж (473)204-51-73,
Екатеринбург (343)384-55-89, Казань (843)206-01-48, Краснодар (861)203-40-90,
Красноярск (391)204-63-61, Москва (495)268-04-70, Нижний Новгород (831)429-08-12,
Новосибирск (383)227-86-73, Ростов-на-Дону (863)308-18-15, Самара (846)206-03-16,
Санкт-Петербург (812)309-46-40, Саратов (845)249-38-78, Уфа (347)229-48-12
Россия, Казахстан и другие страны ТС. Доставка в любой город
Единый адрес для всех регионов: enk@nt-rt.ru || ermaksan.nt-rt.ru