

По вопросам продаж и поддержки обращаться:
Астана +7(7172)727-132, Волгоград (844)278-03-48, Воронеж (473)204-51-73,
Екатеринбург (343)384-55-89, Казань (843)206-01-48, Краснодар (861)203-40-90,
Красноярск (391)204-63-61, Москва (495)268-04-70, Нижний Новгород (831)429-08-12,
Новосибирск (383)227-86-73, Ростов-на-Дону (863)308-18-15, Самара (846)206-03-16,
Санкт-Петербург (812)309-46-40, Саратов (845)249-38-78, Уфа (347)229-48-12
Россия, Казахстан и другие страны ТС. Доставка в любой город
Единый адрес для всех регионов: enk@nt-rt.ru || ermaksan.nt-rt.ru

Innovative Technologies.



CNC HVR SERIES
Variable Rake Hydraulic Guillotine Shear

ERMAKSAN
METAL FABRICATING MACHINERY



80.000 sqm

Largest manufacturing facility
under one roof in Europe
in its sector.



ERMAKSAN is well known for productive and result oriented research & development activities as well as affordable high-tech products in fabricating industry. With 47 years of manufacturing experience ERMAKSAN continuously invests on latest technology and its human resources.

ERMAKSAN manufactures 3000 machines annually with 700 qualified staff in a fully modernized 80.000 sqm factory equipped with state-of art machinery. ERMAKSAN exports 80% of its production through agents under the brand ERMAK from Canada to New Zealand, more than 70 countries in the world and provides full technical support since 1965.

By purchasing ERMAK machines, you will be investing on your future. With this decision we promise you to deliver the machine which will suit your needs and provide the best purchasing experience by means of price, delivery, quality, training and after-sales technical support.

ERMAKSAN
METAL FABRICATING MACHINERY

InnovativeTechnologies.



28.000

Double sided machining capacity of
28.000 mm single part.



3.000

3.000 machines manufactured annually.

CNC HVR SERIES

Variable Rake Hydraulic Guillotine Shear

ERMAKSAN, known as one of the top world wide manufacturer in sheet metal industry, proudly announces its latest shear model to the market, which we call it Variable Rake Hydraulic Guillotine Shear "CNC HVR".

Blade gap, cutting angle and cutting length adjusted based on material selection and thickness automatically. While providing flexibility for different production parts and waste of time has been completely eliminated by aiming high efficiency.

By choosing CNC HVR which is improved by the engineers of ERMAKSAN, you will bring the modern-day technology to your company with maximum safety, high accuracy and unique ease of use.

Excellent cut perfect speed;

It can cut all kind of metal sheet to maintain the highest production capacity with maximum precision and quality.



Excellent cut perfect speed



ERMAK

CNC HVR 4100 X 13

Front support arms.
1 meter (39") long, measured by mm / inch
strong front support arms with T slot and stopper.

Rigid structure.
Processed with high precision,
dynamic and static rigidity provided strong body.



GENERAL FEATURES

User-Friendly

- Wide, bright, colorful touch screen to program easily.
- Easy control pages.
- Complete part programming in seconds.
- Quick machine set up with EasyCut page.
- Contextual help and warning pup-up.

Improved Features

- Auto shutdown function for energy saving.
- 10 different language selection.
- Working time.
- Wireless communication via PC/Laptop (optional).
- Backgauge auto-retraction programming.

Better Cuttings

- Automatic calculations of cutting functions upon material specifications.
- More cutting sequence and programming memory.





STANDARD CONTROLLERS

GENERAL FEATURES

- Keyboard with big buttons.
- Programmed material types.
- Blade gap, cutting angle and cutting length adjusted based on material selection and thickness automatically.
- Different language selections.
- Backgauge adjustment according to blade gap.
- Sequence repeat function.
- Sub-program and programming loop.
- Highly protected micro processor.
- Monochrome 130 x 75mm LCD Box Panel.
- Data recording with internal SRAM memory.
- Updateable with flash memory (optionally with RS 232).
- Numerically programmable axis data.
- 16 input and output ports (24-32 options).
- EASYCUT page.
- Auto cutting (Flying cut).
- mm/inch conversion.
- Backgauge retraction feature.

The logo for ERMAK, featuring the brand name in a bold, black, sans-serif font with a red vertical bar to the left of the 'E'.

ERMAK



Emergency stop buttons.
Easily reachable buttons.

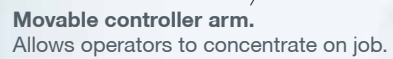

Foot pedal.
Dual positioned pedal allows you to cut automatically.

A grey, adjustable arm extending from the control panel, used for reaching different parts of the machine.

Movable controller arm.
Allows operators to concentrate on job.

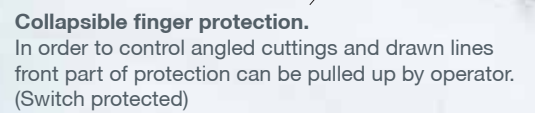
A grey, adjustable safety guard that can be pulled up to allow for angled cuts.

Collapsible finger protection.
In order to control angled cuttings and drawn lines front part of protection can be pulled up by operator. (Switch protected)

**More than
just cutting;**

CNC HVR is developed by expert engineers of ERMAKSAN reflects innovative technology with all aspects of it.



CNC HVR 6100 X 20

ERMAK

CNC HVR 3100 X 10

Squaring arm.
Makes it easy to handle the work and feeds the material through the cutting area by providing more delicate and quicker cuttings.

Front finger protection.
Finger protection that matches with international safety standards, presents a great visual working area to operator.



Light barrier.
Fast and secure protection at all time compatible with CE standards.

Rear sheet sliding plates.
Cutting parts are carried out rapidly to the back side of shear.

Motorized back gauge system.
1000 mm long back gauge with 0.1 mm accuracy.



Defining standards

Standard Equipments

- Wear resistant blades.
 - top blade = 4 cutting edge
 - bottom blade = 4 cutting edge
- Portable foot pedal is eligible for single and automatic cutting.
- CNC controlled hydraulic blade gap adjustment system.
- CNC controlled cutting angle adjustment system.
- CNC controller (CYBELEC).
- CNC controlled motorized backgauge system.
- 1000 mm motorized back gauge system with 0.1 mm accuracy.
- Front support arms with T slot, ruler and flip stop.
- Squaring arm.
- Scales with metric and inches.
- Cutting line illumination and shadow line.
- Emergency stops.
- Sliding sheets.
- Swing up backgauge.
- Stainless blades.

Optional Equipments

- Pneumatic sheet support systems for thin materials.
 - Bar type pneumatic sheet support system.
 - Monoblock type pneumatic sheet support system.
- 0° - 180° angle gauge.
- Long and powered squaring arm with ruler.
- 500 mm and over throat depth.
- Oil cooler.
- Laser cutting line.
- Sliding support arms.
- Finger guard curtains.
- Anti - Twist system.
- Special back gauge stroke
- Different colors.
- Dynamic servo backgauge.
- Sheet feeding system.
- Conveyor.
- Scrap separator.
- Stacker systems.
- X1, X2 adjustable angled backgauge system.
- Blades for stainless steel cutting.



Perfect design in every aspect;

ERMAKSAN improves its reliability every day by working with highly educated engineers and by using the latest technology in rapidly developing sheet metal industry.

By using world standard steel, hydraulic systems and electronic products all your production needs provided.

Anti-Twist system. (option)

Anti-Twist system prevents cutting sheet material from twisting in narrow and strip cuttings by holding straight during the cutting process against to blade movements.

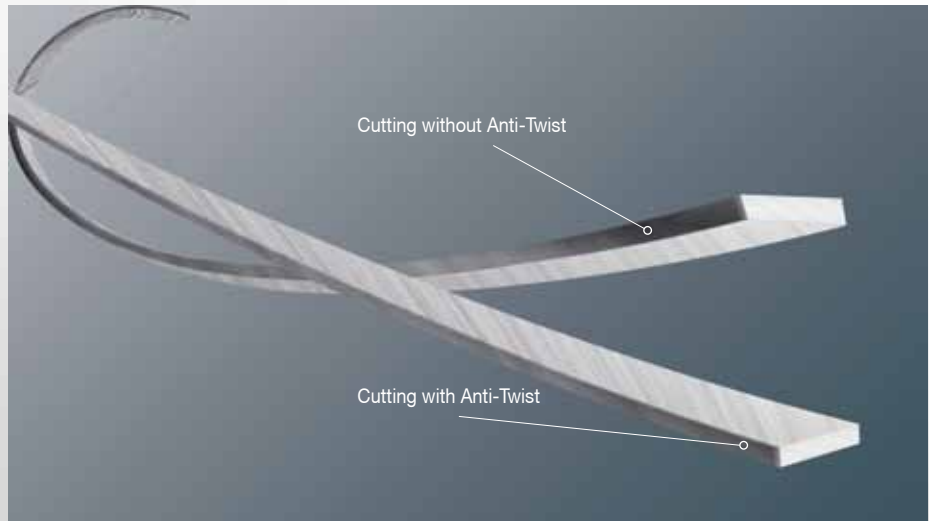

8100 x 6 mm CNC HVR

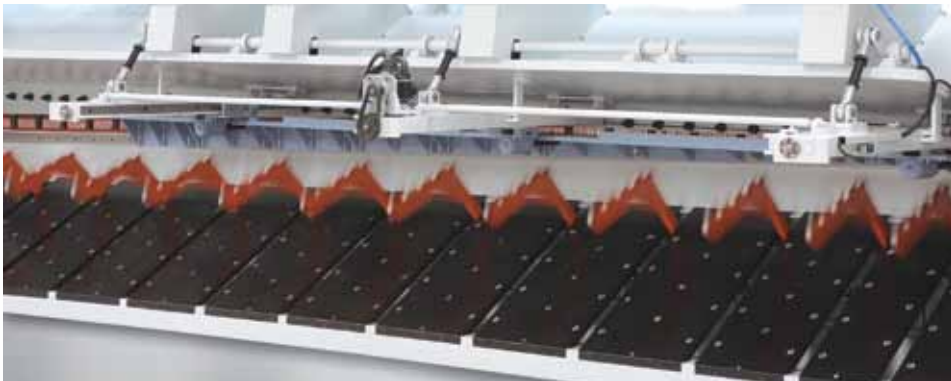

Pneumatic support system. (lever type) (option)

Pneumatic sheet support system provides user an easy method of working, is an optional function to protect sheets hanging down and to improve precision during long and thin sheets cutting with minimum scratches through plastic rolls on pneumatic sheet support system.



Pneumatic support system. (monobloc panel type) (option)

Helps positioning thick and thin sheet metals with sensitive reinforced pneumatic system structure without sagging.

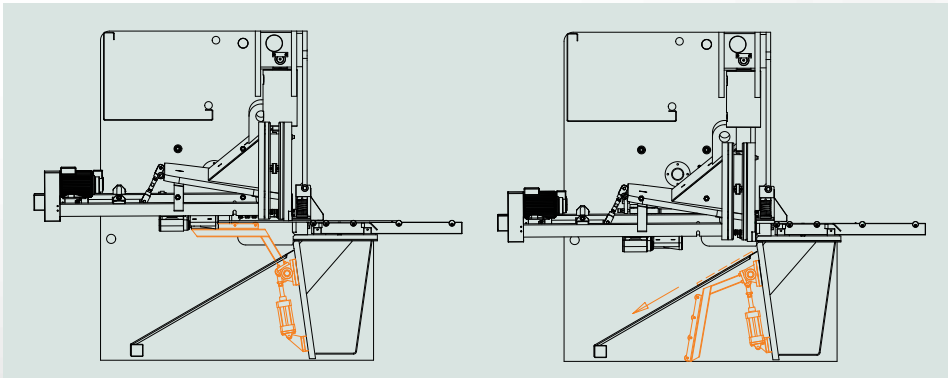

Pneumatic support system (lever type) working principle.

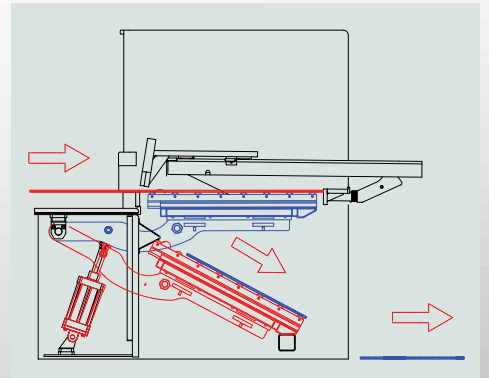

Pneumatic support system (monobloc panel type) working principle.



3100 x 40 mm CNC HVR

CybeleC DNC 61G.
Easier to use with multifunctional control technology.

Special production machines.
Expert engineering in special machine production.



Throat. (standard)
350mm standard throat depth allows you to cut sheet metals that are longer than machine length.

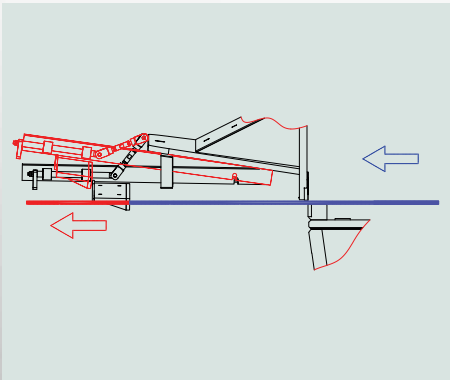

Swing-Up backgauge. (standard)
Enables to cut sheet metals that are longer than backgauge stroke.



Front sheet metal feeding system. (option)
Adjustable width, high accurate and fast front metal sheet feeding system will increase your productivity.

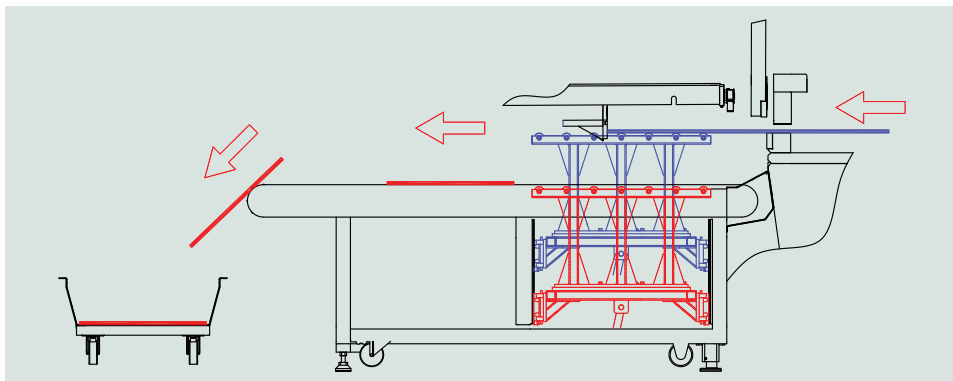

Conveyor system working principle.



Laser cutting line. (option)

With the help of laser cutting line, angled or drawn line cuttings could be done easily and controllable.



Shadow line. (standard)

Provides qualified and sensitive cutting by casting a line shadow at the cutting edge for right positioning of the worksheet to be cut.



Angle gauge. (option)

This device provides accurate and easy material handling in the angled cuttings.



Collapsible finger protection. (standard)

In order to control angled cuttings and drawn lines front part of protection can be pulled up by operator. (Switch protected)

CNC HVR SERIES

Variable Rake Hydraulic Guillotine Shear

Technical Features

TYPE	CUTTING LENGTH	CUTTING CAPACITY (42kg/mm ²)	CUTTING CAPACITY (70kg/mm ²)	CUTTING ANGLE	STROKE PER MINUTE	NUMBER OF HOLD DOWNS	PRESSURE	MAIN MOTOR	BACK GAUGE MOTOR	BACK GAUGE STROKE	OIL CAPACITY
	A										
	mm	mm	mm	(°)	1/min	piece	ton	kW	kW	mm	lt.
CNC HVR 3100 - 6	3100	6	4	0.5 - 1.5	16 - 24	14	12	11	0.75	1000	150
CNC HVR 3100 - 10	3100	10	6	0.5 - 2	12 - 22	14	24	22	1.1	1000	260
CNC HVR 3100 - 13	3100	13	8	0.5 - 2	11 - 20	14	31	22	1.1	1000	310
CNC HVR 3100 - 16	3100	16	10	0.5 - 2.5	9 - 16	14	42	30	1.1	1000	500
CNC HVR 3100 - 20	3100	20	13	0.5 - 2.5	7 - 13	14	54	37	1.1	1000	500
CNC HVR 3100 - 25	3100	25	15	0.5 - 2.5	6 - 10	20	76	45	1.1	1000	800
CNC HVR 3100 - 30	3100	30	18	0.5 - 3	4 - 7	20	100	45	1.5	1000	800
CNC HVR 3100 - 35	3100	35	20	0.5 - 3	4 - 7	20	125	55	2.2	1000	800
CNC HVR 3100 - 40	3100	40	25	0.5 - 3	2 - 4	20	150	75	2.2	1000	1000
CNC HVR 4100 - 6	4100	6	4	0.5 - 1.5	14 - 22	18	15	11	0.75	1000	150
CNC HVR 4100 - 10	4100	10	6	0.5 - 2	10 - 17	18	28	22	1.1	1000	260
CNC HVR 4100 - 13	4100	13	8	0.5 - 2	9 - 15	18	40	22	1.1	1000	310
CNC HVR 4100 - 16	4100	16	10	0.5 - 2.5	7 - 13	18	52	30	1.1	1000	500
CNC HVR 4100 - 20	4100	20	13	0.5 - 2.5	6 - 11	18	67	37	1.1	1000	500
CNC HVR 4100 - 25	4100	25	15	0.5 - 2.5	5 - 9	25	88	45	1.1	1000	800
CNC HVR 4100 - 30	4100	30	18	0.5 - 3	3 - 5	25	120	45	1.5	1000	800
CNC HVR 4100 - 35	4100	35	20	0.5 - 3	3 - 5	25	145	55	2.2	1000	800
CNC HVR 4100 - 40	4100	40	25	0.5 - 3	2,5 - 4	25	170	75	2.2	1000	1000
CNC HVR 6100 - 6	6100	6	4	0.5 - 1.5	9 - 15	26	20	22	1.1	1000	260
CNC HVR 6100 - 10	6100	10	6	0.5 - 2	8 - 13	26	44	22	1.1	1000	260
CNC HVR 6100 - 13	6100	13	8	0.5 - 2	6 - 11	26	60	22	1.1	1000	310
CNC HVR 6100 - 16	6100	16	10	0.5 - 2.5	5 - 9	26	76	30	1.1	1000	500
CNC HVR 6100 - 20	6100	20	13	0.5 - 2.5	4 - 7	26	96	37	1.1	1000	500
CNC HVR 6100 - 25	6100	25	15	0.5 - 2.5	3 - 5	36	123	45	1.1	1000	800
CNC HVR 6100 - 30	6100	30	18	0.5 - 3	2 - 3	36	160	45	1.5	1000	800
CNC HVR 6100 - 35	6100	35	20	0.5 - 3	2 - 3	36	180	55	2.2	1000	800
CNC HVR 6100 - 40	6100	40	25	0.5 - 3	1 - 2	36	210	75	2.2	1000	1000

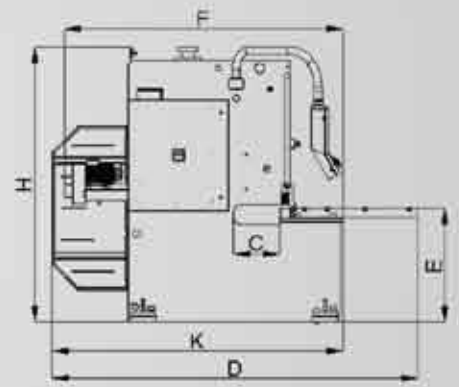
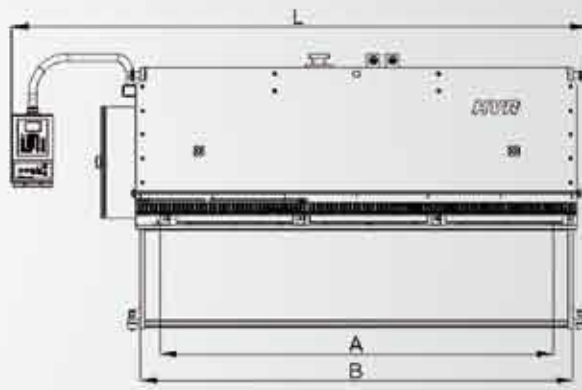

BLADE GAP ADJUSTMENT	BACK GAUGE SPEED	NUMBER PF SHEET SUPPORT ARM	TABLE LENGHT	THORATH DEPTH		MACHINE WIDTH	TABLE HIGH	TRANSPORT WIDTH	LENGHT	WIDTH	HEIGHT	WEIGHT
mm	mm/sec	piece	B mm	C mm Ops. (mm)		D mm	E mm	F mm	L mm	K mm	H mm	kg
0.05 - 0.8	110	2	3500	350	500	2900	900	2200	4980	2315	2225	7050
0.05 - 1.3	110	2	3640	350	500	3000	910	2265	5100	2425	2250	10230
0.05 - 1.5	110	2	3680	350	500	3100	900	2315	5110	2570	2400	12650
0.05 - 1.9	110	2	3760	350	500	3240	900	2340	5210	2700	2450	16500
0.05 - 2.3	110	2	3800	350	500	3240	900	2355	5220	2700	2550	18900
0.05 - 3.0	110	2	3880	350	500	3240	1000	2430	5250	2725	2900	27600
0.05 - 4	110	2	3835	350	500	3760	1100	2750	5560	2750	3280	43000
0.05 - 4.5	110	2	4000	350	500	3850	1150	2900	5725	2900	3600	56500
0.05 - 5.5	110	2	4030	350	500	4180	1150	3030	6070	3030	4360	73000
0.05 - 0.8	110	3	4500	350	500	2900	950	2200	6000	2315	2320	10250
0.05 - 1.3	110	3	4640	350	500	3150	1000	2270	6100	2580	2460	15100
0.05 - 1.5	110	3	4680	350	500	3240	1000	2325	6120	2700	2600	18450
0.05 - 1.9	110	3	4760	350	500	3240	1000	2340	6220	2700	2700	23200
0.05 - 2.3	110	3	4800	350	500	3270	1000	2355	6220	2700	2700	26700
0.05 - 3.0	110	3	4880	350	500	3240	1100	2440	6500	2725	3235	37700
0.05 - 4	110	3	4920	350	500	3450	1150	2700	7000	2700	3500	58500
0.05 - 4.5	110	3	5050	350	500	3450	1150	2800	6450	2800	3600	82500
0.05 - 5.5	110	3	5200	350	500	3500	1150	2800	6600	3200	3825	95500
0.05 - 0.8	110	5	6660	350	500	3175	1000	2285	8250	2475	2725	26415
0.05 - 1.3	110	5	6680	350	500	3150	1100	2285	8265	2575	2725	28800
0.05 - 1.5	110	5	6720	350	500	3050	1100	2330	8365	2635	2825	33300
0.05 - 1.9	110	5	6820	350	500	3240	1100	2350	8400	2700	2995	37600
0.05 - 2.3	110	5	6940	350	500	3210	1100	2375	8415	2730	3120	50600
0.05 - 3.0	110	5	7020	350	500	3185	1200	2480	8570	2730	3390	68500
0.05 - 4	110	5	6915	350	500	3500	1200	2700	9000	2700	3800	88000
0.05 - 4.5	110	5	7150	350	500	3550	1200	2800	8700	3950	3850	100700
0.05 - 5.5	110	5	7030	350	500	4120	1250	3790	9550	3790	5820	162500

По вопросам продаж и поддержки обращаться:

Астана +7(7172)727-132, Волгоград (844)278-03-48, Воронеж (473)204-51-73,
Екатеринбург (343)384-55-89, Казань (843)206-01-48, Краснодар (861)203-40-90,
Красноярск (391)204-63-61, Москва (495)268-04-70, Нижний Новгород (831)429-08-12,
Новосибирск (383)227-86-73, Ростов-на-Дону (863)308-18-15, Самара (846)206-03-16,
Санкт-Петербург (812)309-46-40, Саратов (845)249-38-78, Уфа (347)229-48-12

Россия, Казахстан и другие страны ТС. Доставка в любой город

Единый адрес для всех регионов: enk@nt-rt.ru || ermaksan.nt-rt.ru